

PRODUCT SPECIFICATIONS

DMXREW1 / DMXREW2

DMXREW1

DMXREW2

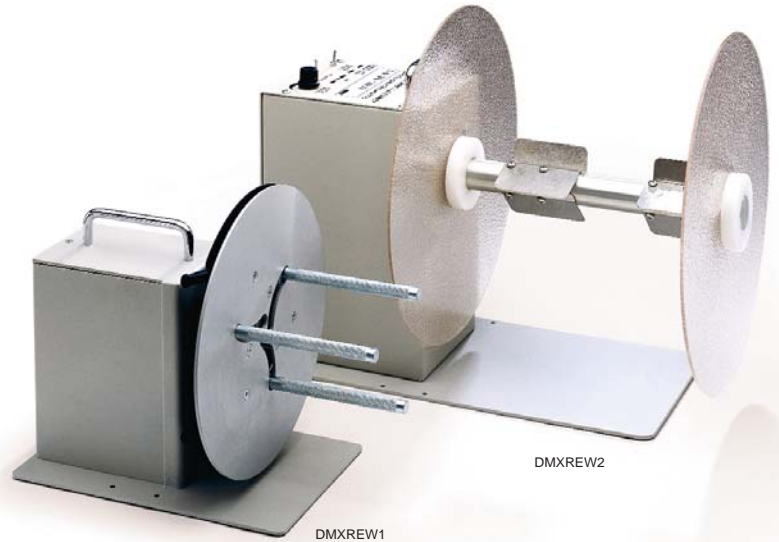

DMXREW1

The DMXREW1 Label Rewinder/ Unwinder is capable of rewinding or dispensing label rolls up to 4 inches wide, up to 8 inches in diameter at speeds up to 10 ips (inches per second). The DMXREW1 has a precision-crafted Adjustable Core Holder that adjusts in seconds to accept any core diameter from 1 inch to 4 inches (25 to 102mm). You can also do coreless rewinding with the DMXREW1.

The DMXREW1 uses Constant Adjustable Torque™ technology to achieve impressive, reliable performance at an unprecedented low price. A special motor, designed specifically for the DMXREW1, offers bi-directional operation and trouble-free performance. A switch conveniently controls the amount of rewind force. No awkward tensioning arms, troublesome belts, or clutches are used and no speed adjustments are required. Your DMXREW1 automatically adjusts to any printer speed up to 10 ips and even automatically allows label back-feeding if your printer requires it.

The DMXREW1 has an inner label flange to keep the edge of the label web aligned as the labels are being rewound. Rugged steel construction allows your DMXREW1 to simply be set in place near your label printer. Special anti-slip feet prevent the unit from moving.

DMXREW2

The Constant Adjustable Torque™ technology makes the DMXREW2 silent and easy-to-use. No awkward tensioning arms, troublesome belts or clutches are used. Instead a powerful direct drive motor, designed especially for the DMXREW2, and driven by advanced control circuitry, ensures constant, uniform rewind torque. The result is a short leader length, exceptionally easy threading, no speed adjustments, trouble-free performance, and unsurpassed reliability!

A Torque Control knob allows you to set precisely the amount of rewind force desired. The bi-directional DMXREW2 adjusts automatically to any printer speed and even allows for back-feeding labels if your printer requires it. The DMXREW2 Rewinder can also be used as a label Unwinder.

The DATAMAX Heavy-Duty Rewinder is designed for continuous duty operation in rugged environments. Maximum label widths of 9-1/2". The DMXREW2 handles any rewind job and with its "HIGH" torque range can also be used with slitters.

Rugged heavy steel, industrial quality construction allows the DMXREW2s to be simply set in place. Special anti-slip feet prevent the units from moving. Reliable, high quality and maintenance-free, the Heavy-Duty DMXREW2 Label Rewinders feature a Limited 3 Year Parts and Labor Warranty, the longest in the industry. With a DMXREW2 Label Rewinder working for you, you will enjoy a new dimension in label rewinding convenience and reliability.



DATAMAX®

DATAMAX®

DMXREW1 SPECIFICATIONS:

Corporate Headquarters
4501 Parkway
Commerce Boulevard
Orlando, Florida USA 32808
(407) 578-8007
Fax (407) 578-8377
http://www.datamaxcorp.com

Datamax International
Herbert House
Elizabeth Way, Pinnacles
Harlow, Essex CM19 5FE UK
+44 1279 772200
Fax +44 1279 424448

Datamax Latin America
4501 Parkway
Commerce Boulevard
Orlando, Florida USA 32808
(407) 523-5520
Fax (407) 578-8377

MODEL	DMXREW1
DESCRIPTION	REW1 for 1" to 4" cores (25 to 100 mm)
LABEL WIDTH	Up to 4.5-inches (113 mm). Maximum Label Roll Weight: 8.5 lbs. (3.9 kg)
ROLL DIAMETER	8" (200mm)
MAX SPEED	10 ips (250mm/sec.)
LABEL ROLL DIAMETER	Up to 8-inches (200 mm)
CORE DIAMETER	Use any cardboard core from 1- to 4-inches (25 to 102mm) in diameter
SPEED	Up to 10-ips (25+ mm/sec). Switch adjustable rewind force. No speed adjustments are required
START/STOP	Convenient ON-OFF switch
DIRECTION	Bi-directional
POWER REQUIREMENTS	120vac 60Hz. UL / CSA or 220vac 50 Hz. CE Listed Power Supplies
DIMENSIONS	9H x 6W x 11D" (229 x 152 x 279 mm). Weight: 13 lbs. (5.9 kg)
WARRANTY	Limited 3-Year Parts and Labor Warranty. (One [1] Year Limited Warranty on included Power Supply Module)

DMXREW2 SPECIFICATIONS:

Asia-Pacific Sales
19 Loyang Way
#01-01 CILC Building
Singapore 508724
+65 542-2611
Fax +65 542-3611

MODEL	DMXREW2
DESCRIPTION	REW2 for labels up to 9.5" wide. For 3" cores
LABEL WIDTH	Up to 9.5"
ROLL DIAMETER	Up to 12"
MAX SPEED	Up to 30 ips; bi-directional
TORQUE ADJUST	Continuously adjustable torque and braking control
TORQUE RANGE	NORMAL (REWIND), HIGH (SLIT); "EXTERNAL HALT CONTROL" – External control removes power to the motor and applies braking
DIMENSIONS	12.75H x 15W x 12.5D" (324 x 381 x 318mm)
BASE PLATE FOOTPRINT	7 x 15" (180 x 356mm). Weight: Approximately 23lbs (10.5kg)
POWER REQUIREMENTS	120vac 60Hz 50 va. UL Listed Power Supply Or 240vac 50 Hz CE Power supply
WARRANTY	Limited 3-Year Parts and Labor Warranty. (One [1] Year Limited Warranty on included Power Supply Module)



DATAMAX